

EPS Foam Densification System

Loose EPS Foam
truckload weights of
2,000 lbs.*



Baled EPS Foam
truckload weights of
6,000 lbs.*



Densified EPS Foam truckload weights up to 40,000 lbs. *

- Reduced handling costs and storage requirements
- Eliminates pentane gas dangers
- Up to 300 lbs per hour with 1.5# EPS
- Superior performance
- Minimal maintenance
- 15 to 22 lbs per cubic foot



* Truckload weights listed are approximate

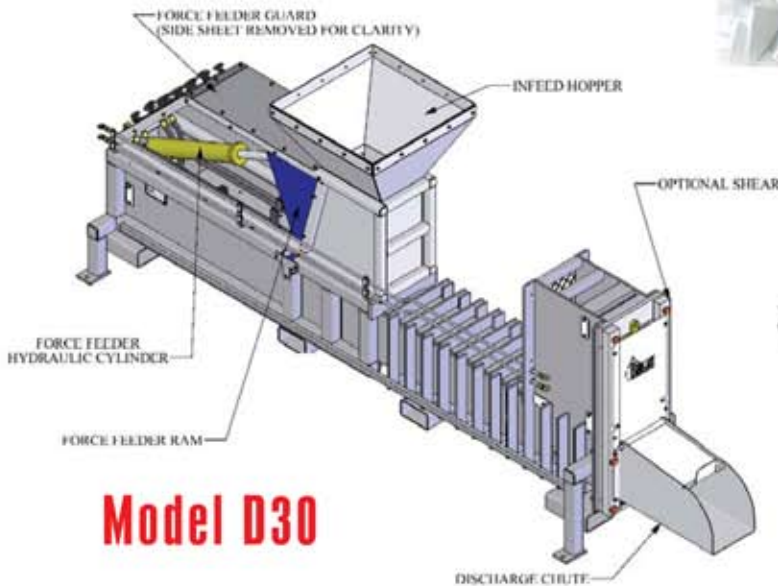

Model D30



Working together to provide
complete
waste and recycle processing solutions

1-800-464-3095



The Densification Specialists

Sebright

Stationary Compactors
Self-contained Compactors
Precrushers
Hydraulic Cart Dumpers, Custom Carts and Containers

Bright

Belt Filter Presses
High Density Extruders
Xtractors
EPS Foam Densifiers

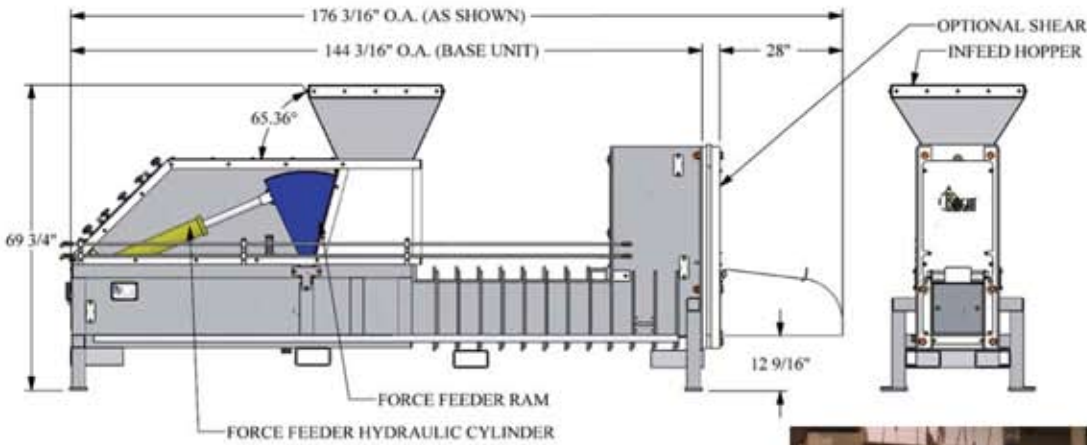
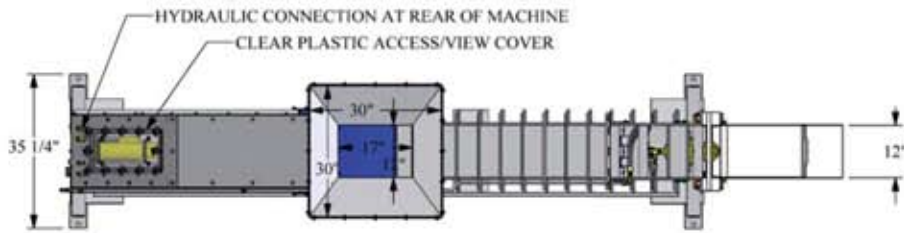

Ship This



Or Ship This

Chamber Volume	Motor	Cylinder	Ram Force	Total Force
.22 cu yards	15 HP	(1) 6" Diameter	490 PSI	71,000 lbs.
Feed Capacity w/1.5# EPS	Volume Compaction Ratio	Output Density	Machine Weight	Power Unit Weight
300 lbs. per hour	Up to 50:1	15-22 lbs./ft ³	3,700 lbs.	1,250 lbs.

Available options include:

- elevation stands
- blower systems
- automated block shears
- discharge snout extensions
- customized EPS Foam pre-breakers
- bag house assemblies

Due to product improvements, the manufacturer reserves the right to alter or amend, without notice, any of these specifications and/or dimensions.

All machines and accessories are primer coated and finish painted. Standard color chart available upon request.

© Sebright Products, Inc. 2008



WASTEC
Waste Equipment Technology Association
Member

